

THE DESCRIPTION OF HIGH SPEED 1+1 FLAT MASK PRODUCTION LINE



力顺源
LISHUNYUAN

(1+1) Model: LY-60KZ

目录

contents



PART 1

产品介绍

Product introduction

PART 2

技术参数

technical parameter

PART 3

设备结构

Equipment structure

PART 4

工作流程

Workflow

PART 5

售后及验收

After sales and acceptance

产品介绍

Product introduction

本设备主要生产平面口罩，由口罩成型机和外耳带焊接机组成。从原材料卷料自动送料、鼻线插入、截断、超声波熔合、口罩自动裁断、耳带上料及焊接等均全自动完成。可按要求定制生产2-4层口罩（无封边），性能稳定，操作简单，成品外观美观，质量上乘，性价比高，符合医用口罩的制作质量要求。

This equipment mainly produces plane mask, which is composed of mask forming machine and outer ear band welding machine. Automatic feeding from raw material roll, inserting and cutting nose line Breaking, ultrasonic fusion, automatic cutting of mask, feeding and welding of ear band are all completed automatically. 2-4 layers of mask (without edge sealing) can be customized, Stable performance, simple operation, beautiful appearance, high quality, high cost performance, in line with the quality requirements of medical masks.



口罩示意图

产品介绍

Product introduction

The line is suitable for the production of outer ear loop flat masks with 2/3/4 layers

Mask sizes: 175*95mm (Standard, for adult)

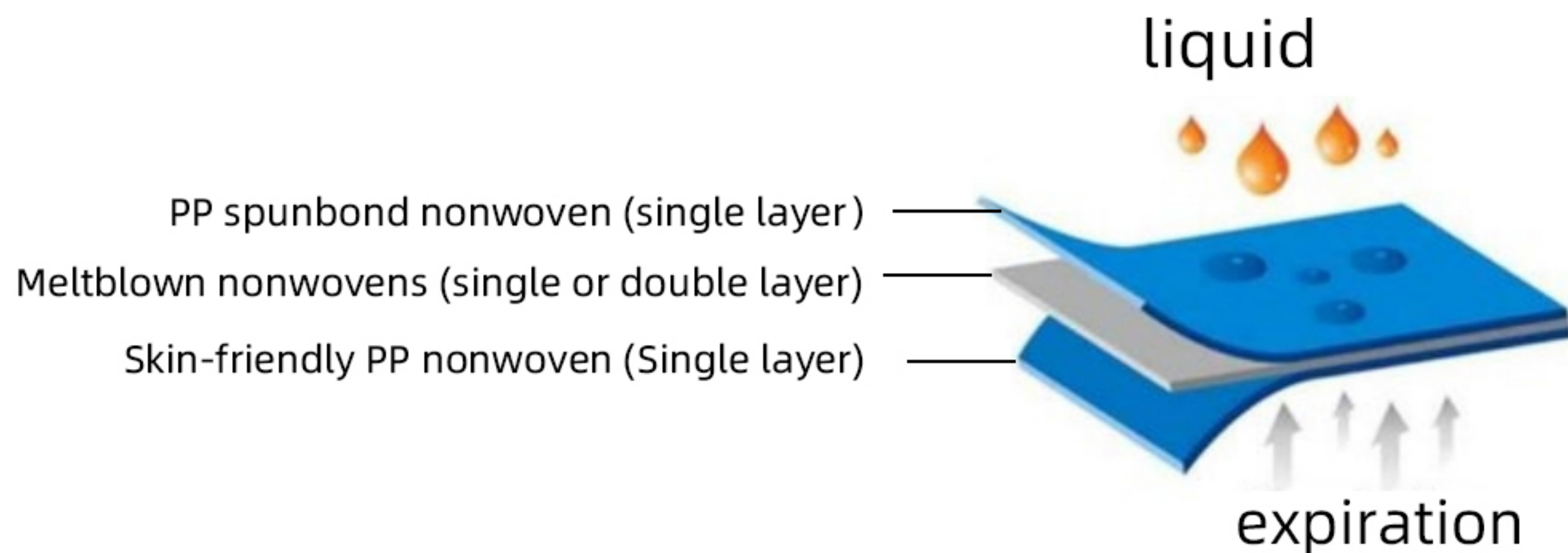

技术参数

technical parameter

Item	Parameters	
Machine Sizes	4116mm*2100mm*1880mm	
Finished Mask Sizes	Standard	175*95mm
	Special	180*95mm
		145*90mm
		125*90mm
Electricity Control System	INOVANCE/XUNJIE	
Power Supply	220V, 50/60Hz, 1P	
Air Pressure	5-6KG/CM ²	
Driven by	Servo & Stepping Motors	
Control Panel	Human-Machine Interface (Touch Screen)	
Applicable Material	PP Nonwoven Fabric & Composite Fiber	
Production Speed	90-120 PCS/MIN	
Power	8KW	
Ultrasonic Frequency	20KHz	
Mask Qualified Rate	99%(Except disqualified masks caused by operation error & disqualified raw material)	

设备结构

Equipment structure

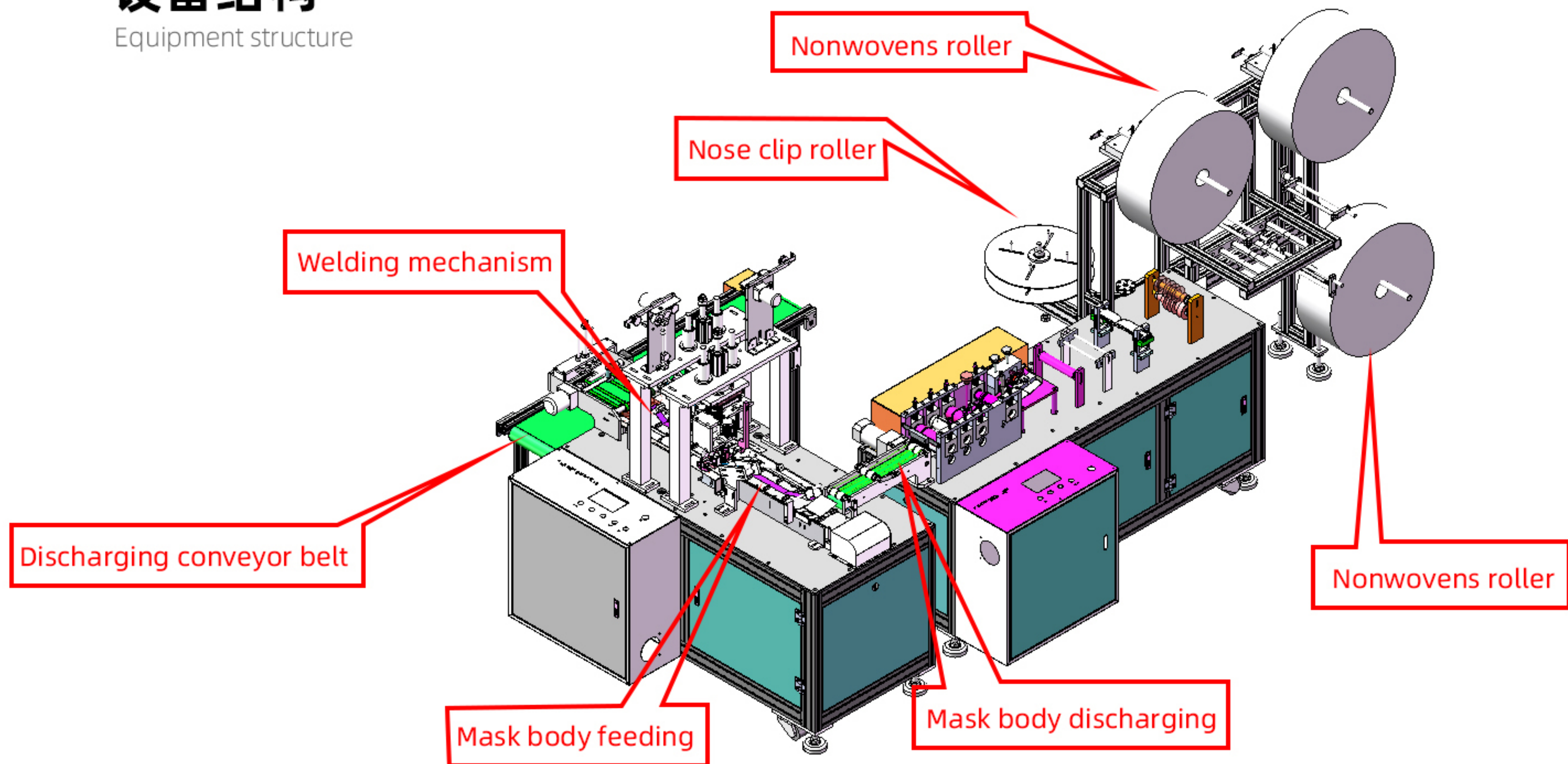

3D外观

3D Appearance

设备结构

Equipment structure

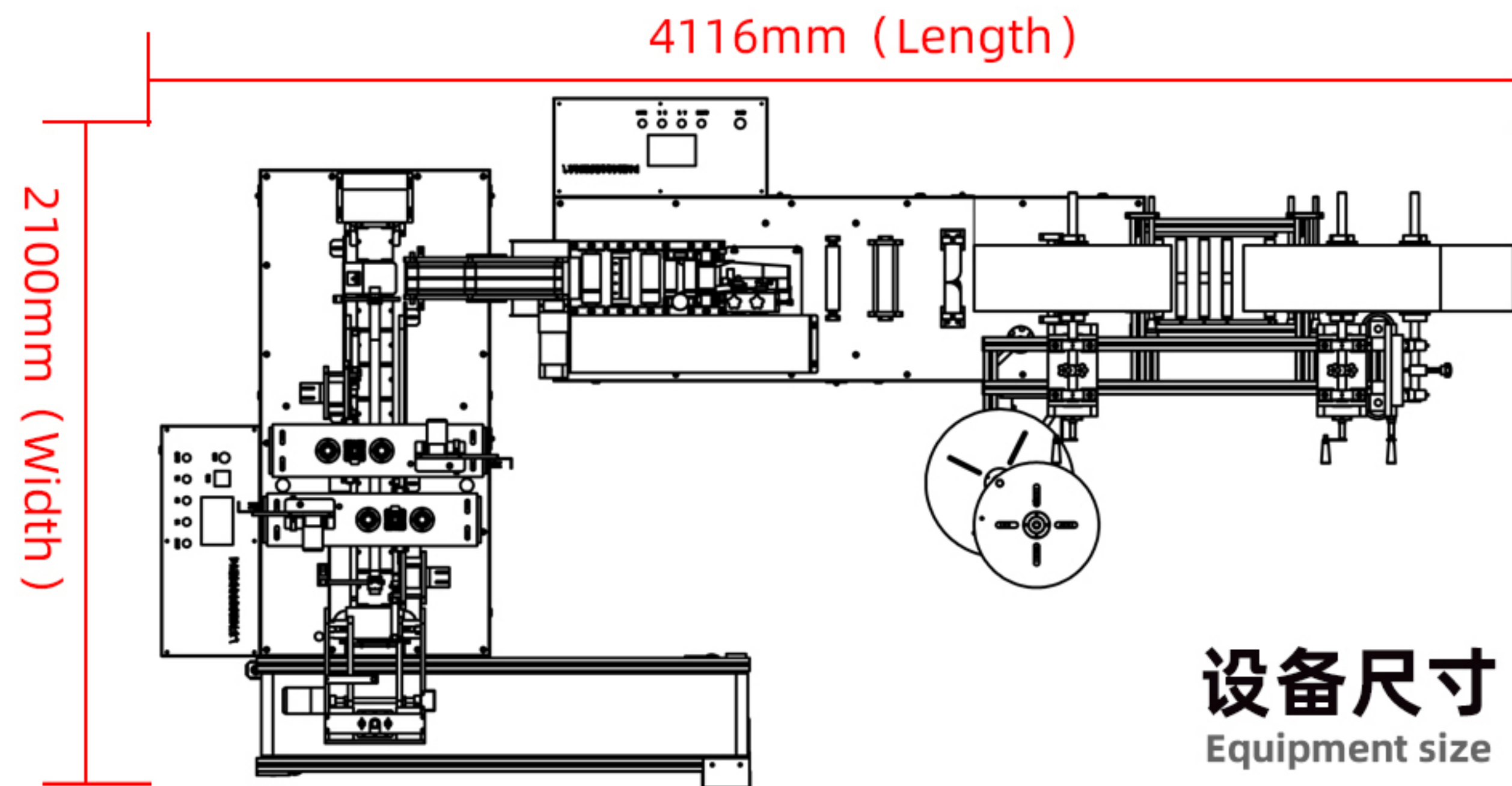

设备尺寸
Equipment size

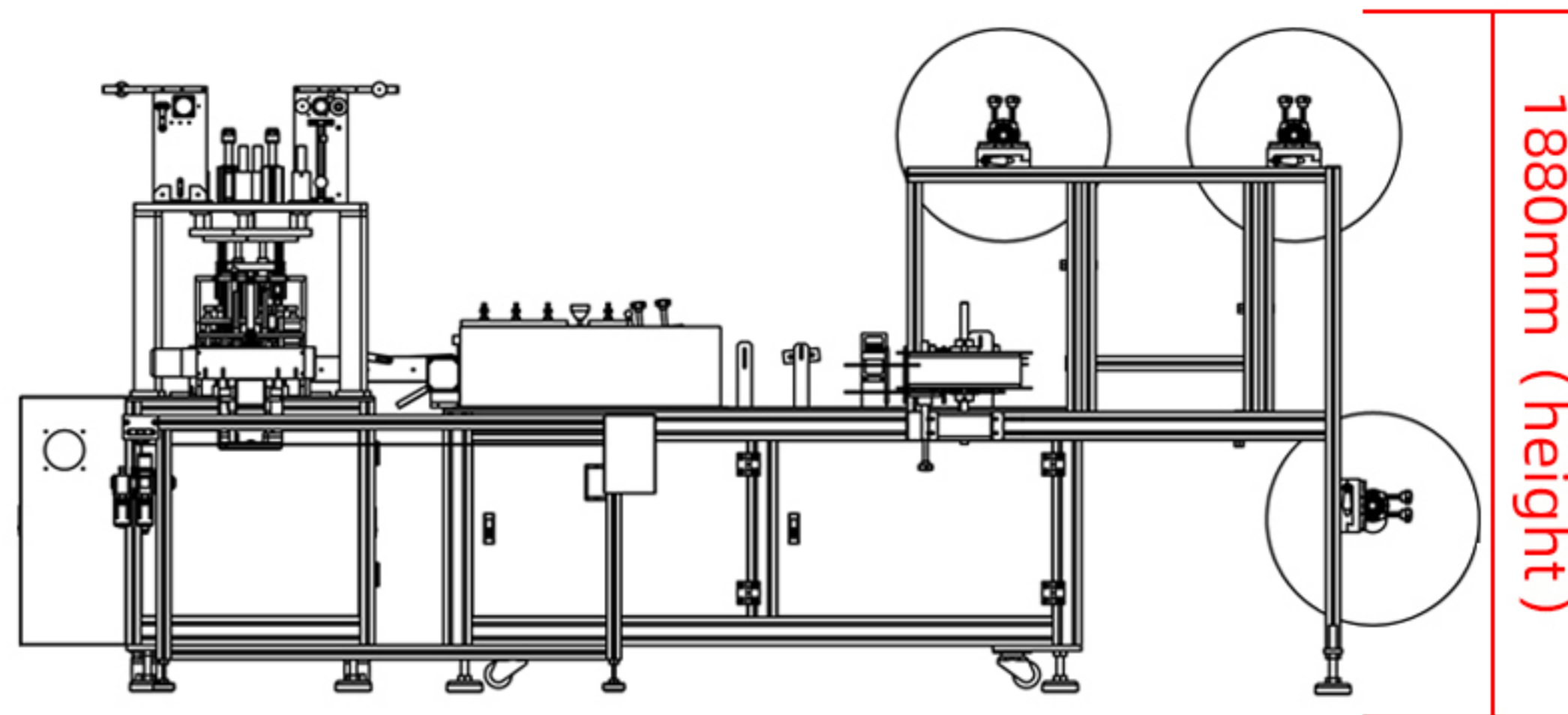

设备结构

Equipment structure

Mask body Forming unit

Ear loop welding unit

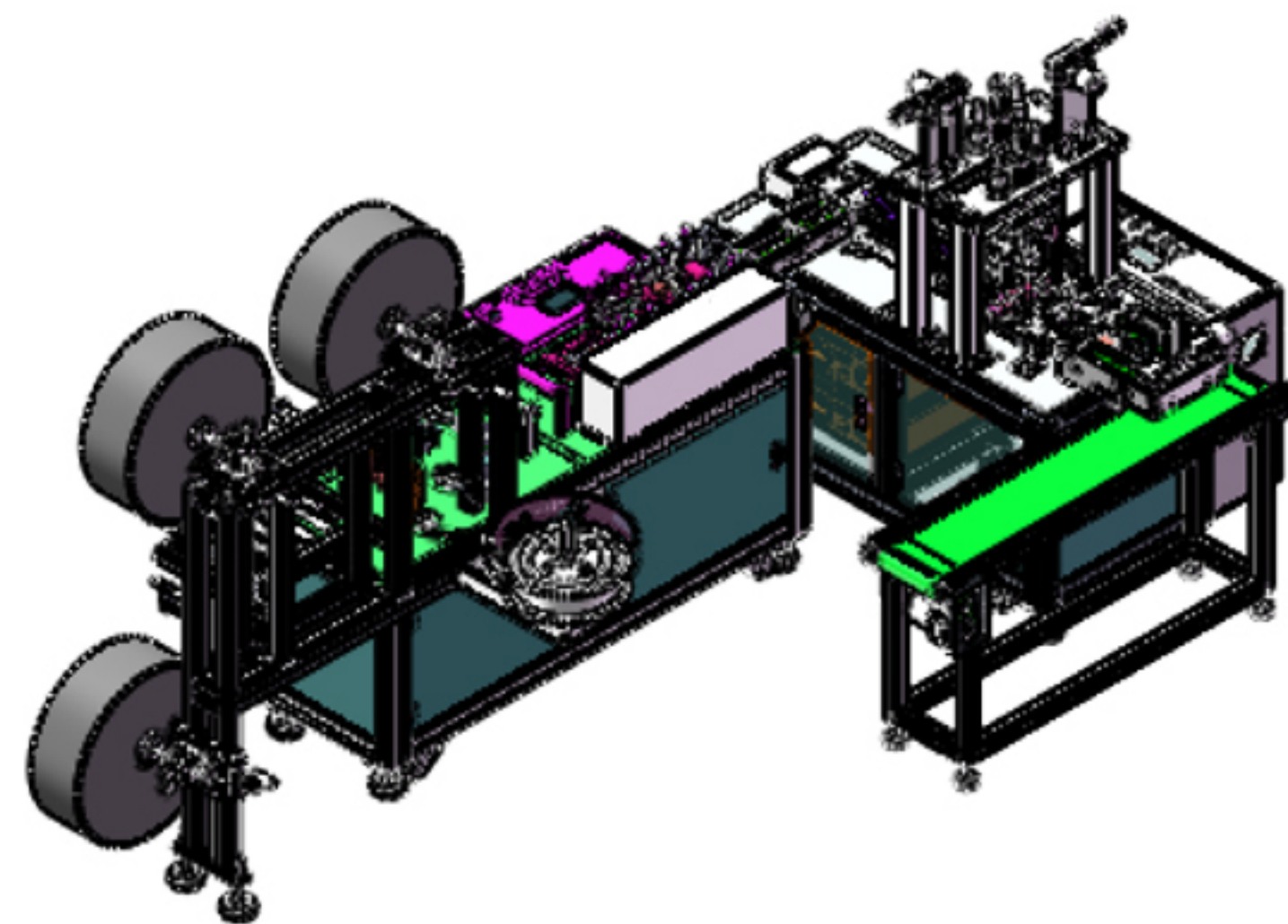
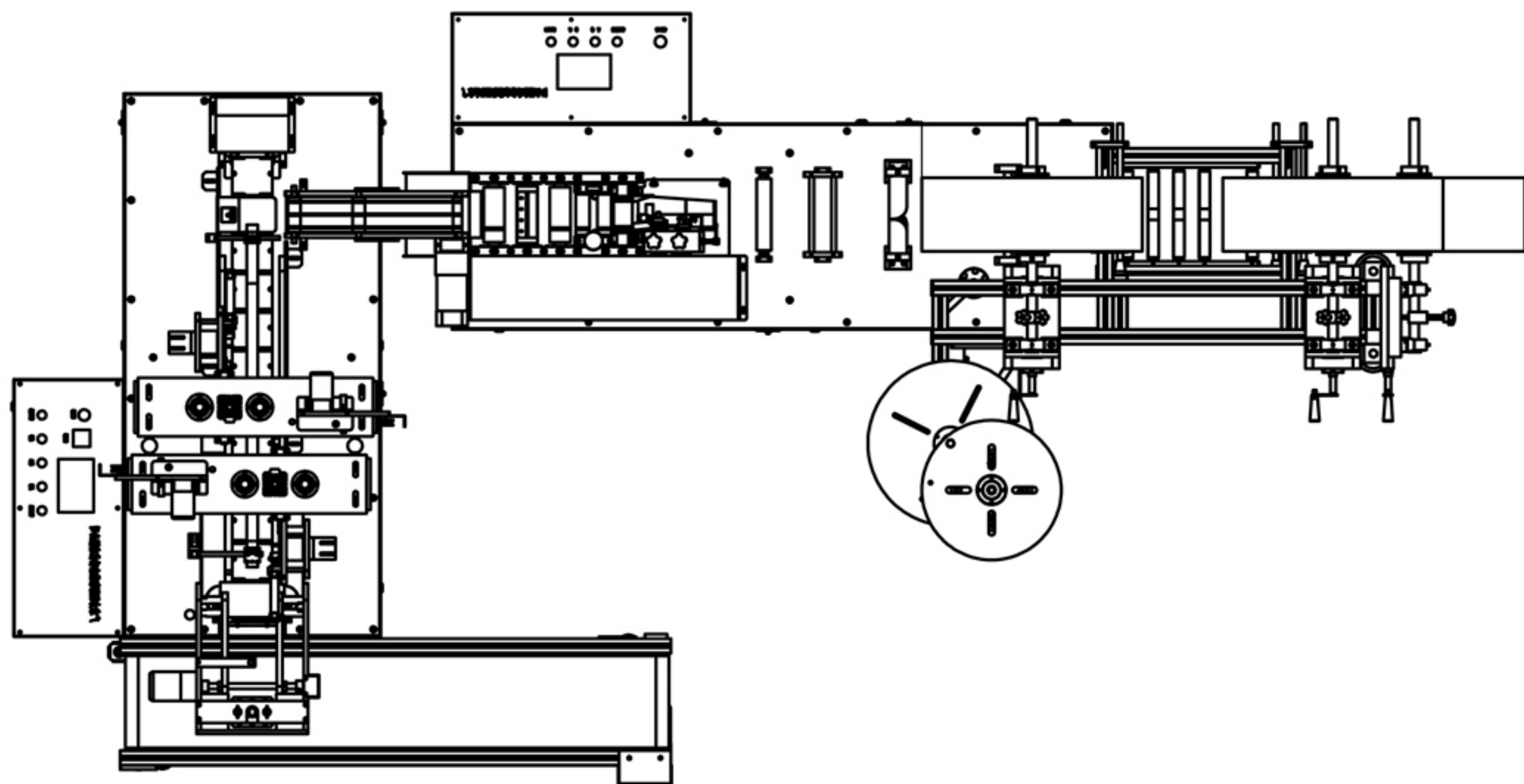

线体:总功率 220V 8KW

total power 220V 8kw

设备结构

Equipment structure

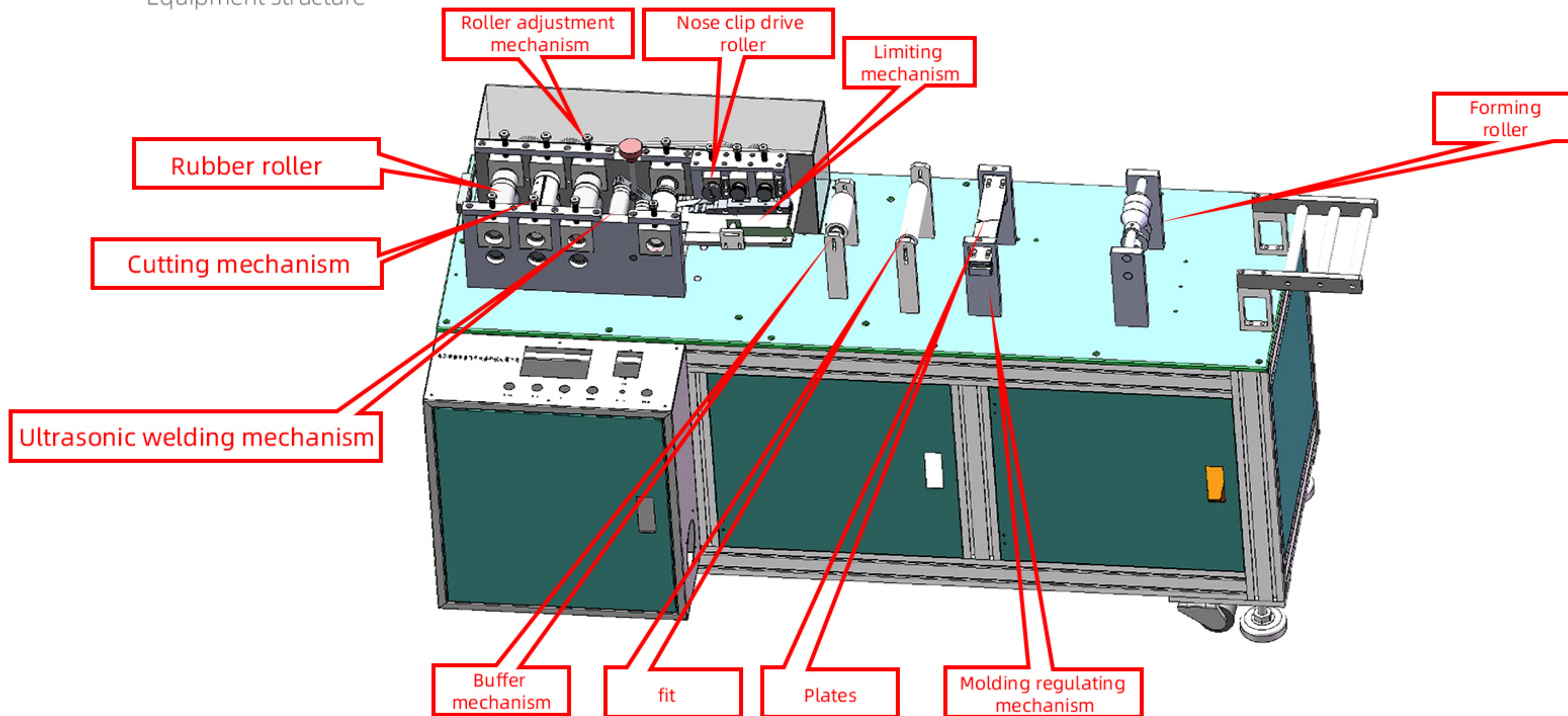

设备结构

Equipment structure

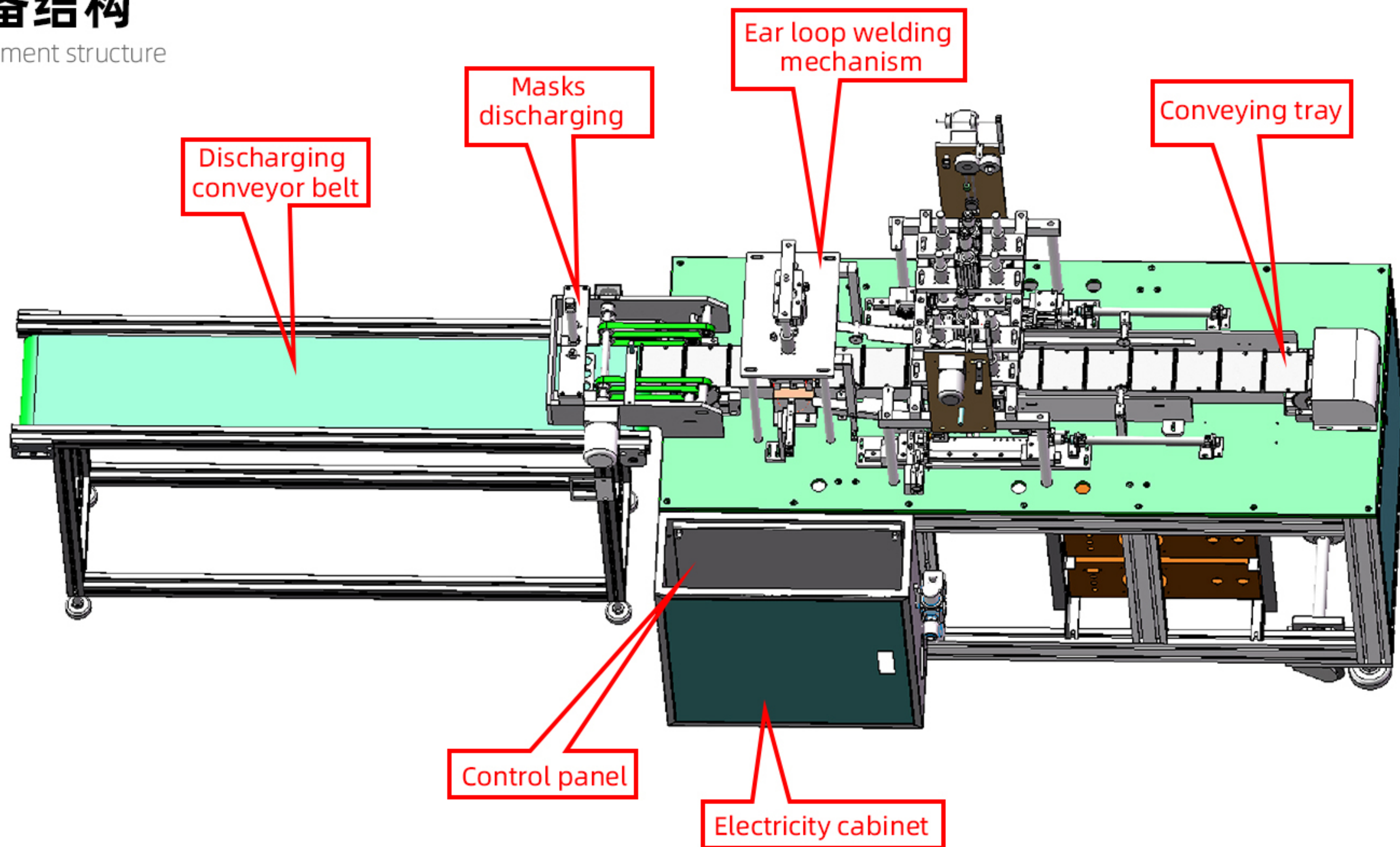

设备结构

Equipment structure

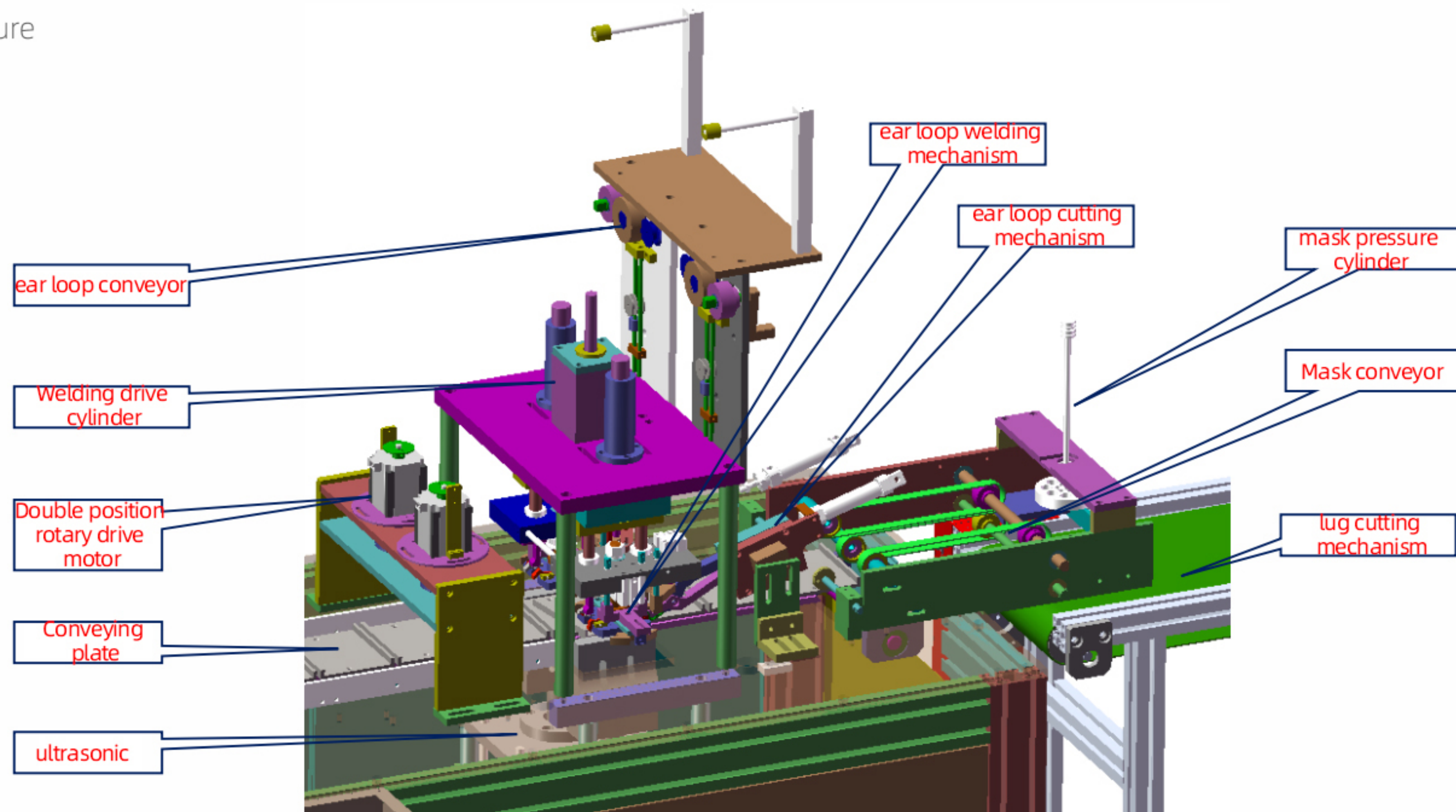

外耳带焊接部分

Welding part of outer ear band

设备工作流程图

Equipment work flow chart

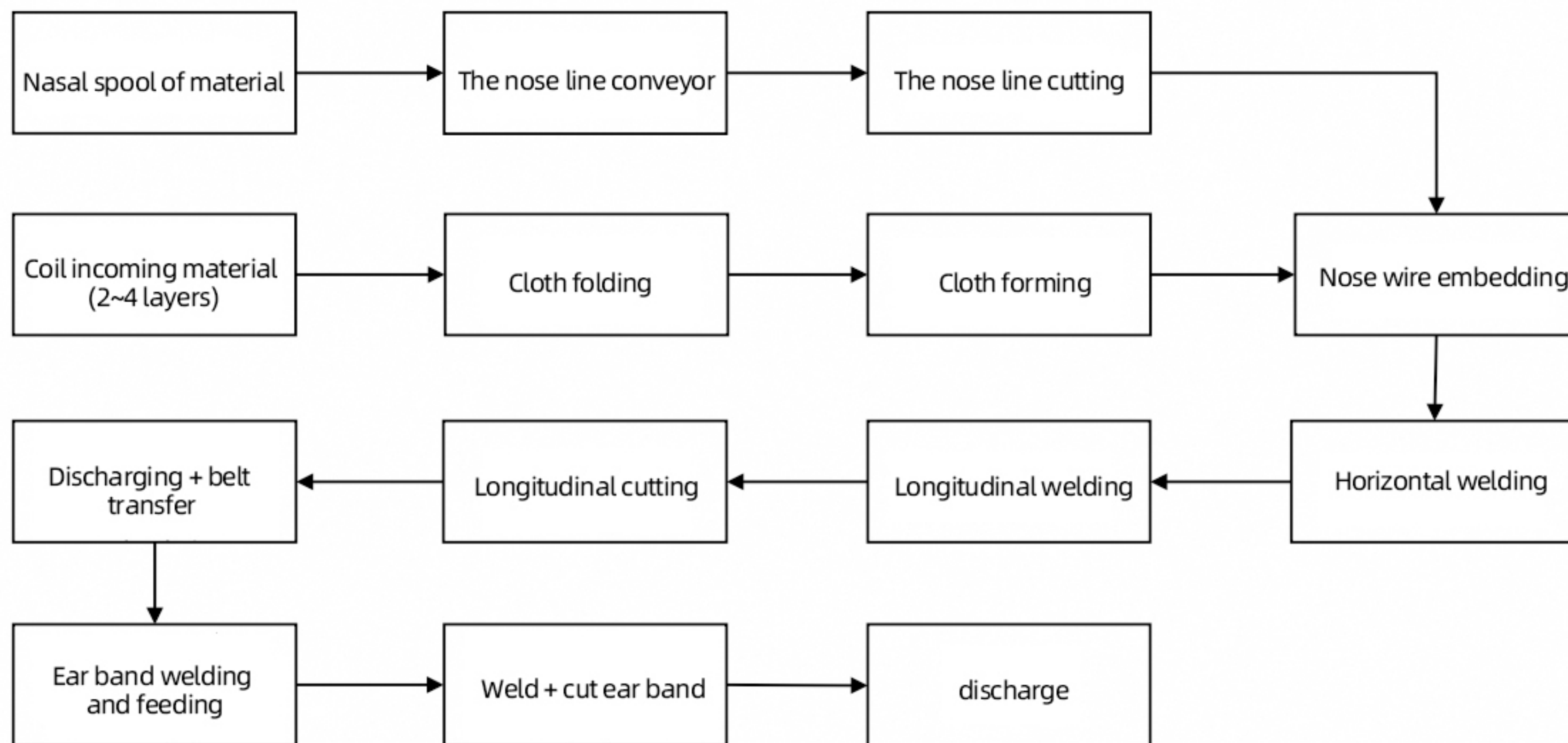

售后及验收

After sales and acceptance

Installation,debugging and training:

- 1、 EXW FACTORY PRICE.
- 2、 Before the equipment is shipped to the buyer's factory, the seller shall be responsible for the installation and debugging of the equipment.
- 3、 Not included installation and training.

Equipment acceptance:

Final Acceptance (Formal Acceptance):

- 1、 Packaging and appearance inspection: the external packaging is not damaged visually, and the appearance of the whole machine is not marked or seriously scratched or breakage, etc.
- 2、 Check the main machine and random accessories: check according to the random packing list.
- 3、 Equipment trial operation check: after small batch trial run, carry out verification.
- 4、 Acceptance time: The contract shall prevail.

售后及验收

After sales and acceptance

After sales and acceptance:

- 1、 The warranty period of the equipment is 12 months from the date of arrival of the equipment. The seller shall maintain the equipment free of charge during the period (except for artificial damage and wearing parts). The buyer shall be responsible for the accommodation and travel expenses of maintenance personnel.
- 2、 After the expiration of the warranty period, the seller is still responsible for the maintenance of the equipment for life, but a reasonable hourly fee and reasonable travel expenses. When it comes to the update and purchase of equipment related parts, the seller only collects the cost of the parts and related fees.
- 3、 In order to ensure the capability and quality of the device, please use the parts and materials required by the specification.
- 4、 Mentioned in this specification book failed to predict the content of performance, as a result of the function of failure will be negotiated additionally, decided to disposal methods
- 5、 During maintenance and fault handling, when touching the device by hand, be sure to cut off power sources such as power supply and cover the blade and protrusion before implementation.

感谢您的聆听

Thanks!



广东力顺源智能自动化有限公司

GuangdongLiShunYuan Intelligent Automation CO.,Ltd

工厂地址：广东省东莞市道滘镇南丫工业区南阁东路

FACTORY ADD: NanGe EastRoad, Nan Ya Industrial Zone, Daojiao Town

Dongguan, Guangdong, China

网址/WEB: WWW.dglyjx.com



力顺源智能服务号